

Documentation for

Stepper motor driver Tiny-Step II

Revision 2.1, Last change: 17.08.2020

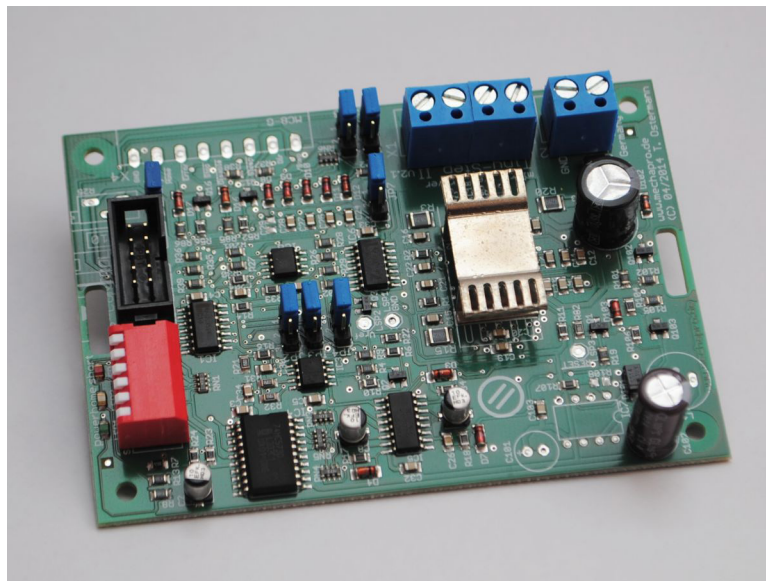

Functional description

Tiny-Step II is a one channel motor driver for 2-phase stepping motors with pulse and direction interface. Motor step size can be set to microstep resolutions down to 1/16th step. The motor output is protected against short circuit. The "mixed decay" current control reduces current noise in the motor coils, which leads to quieter motor movement and higher dynamic in the upper speed range. Thanks to the application of a modern driver stage with low power loss, only a small, soldered heat sink is necessary. The unit can be mounted horizontally or vertically with the designated mounting holes or clipped to a DIN rail with additional DIN rail mounting feet. There is an option available with case for space saving horizontal DIN rail mounting (version "Tiny-Step.plus"). The device can be supplied with different options on request.

Contact:

mechapro GmbH
Im Winkel 34
D-52146 Würselen
Tel.: +49/2405/47937-20
Fax: +49/2405/47937-23
Mail: info@mechapro.de
Web: www.mechapro.de

Technical Data

Supply voltage: 15-35V= and 5V= (max. 20mA), „plus“ Version: 15-38V=
Motor current: adjustable from 0.15 to 2.25A (peak), „plus“ Version 0.15 to 2.40A (peak)
Max. current consumption: 2A
Motor outputs: Short circuit protected
Signal inputs and outputs with 5V logic, no galvanic isolation, inputs 24V tolerant
Case material („plus“ version only): PA 6.6-FR (UL 94 V0)

Exclusion of Liability, EMC (electromagnetic compatibility)

The present stepper motor driver board Tiny-Step II was developed taking all common and established rules into account. It has undergone extremely thorough testing. A guarantee for faultless function in the user's application cannot be provided mechapro® ensures that Tiny-Step II in combination with appropriate controls and appropriate mechanical components for the purpose of this description and manual is basically suitable for the intended purpose.

Any liability for consequential damages or damages for loss of profits, business interruption, loss of information, etc. arising from the use and/or operation of the presented circuitry is excluded.

Cabling (incl. shielding), used amplifiers, power supply, housing and the surrounding environment are factors that influence the EMC properties of a device. A device using one or more Tiny-Step II stepper motor drivers must of course be evaluated according to corresponding directives, when CE conformity must be documented with the CE marking. During development all possible means were used to conform to EMC regulations.

Initial operation

Before using the driver, set the DIP switches and jumpers to the desired settings according to following descriptions. Afterwards the driver can be mounted in a case or cabinet and get wired to the machine and the controller or interface. When all connections are done, the unit is ready to operate.

Connections

The following section gives a brief overview on the functions of the different connectors. Afterwards, the pin outs of the multipolar connectors are given in detail.

- X1 is the clamp for the motor coils.
- X2 is the clamp for the supply voltage. 12V to 35V DC are accepted. Take care of the polarity!
- Clamp X3 is used for the logic input and output signals.
- On the "plus" version with DIN rail case, X1, X2 and X4 are equipped with the pluggable clamps. The I/O signals can be connected to either X3 or X4.
- The DIP switch S1 allows setting the micro step resolution, the motor current and activates the automatic current reduction in standstill.

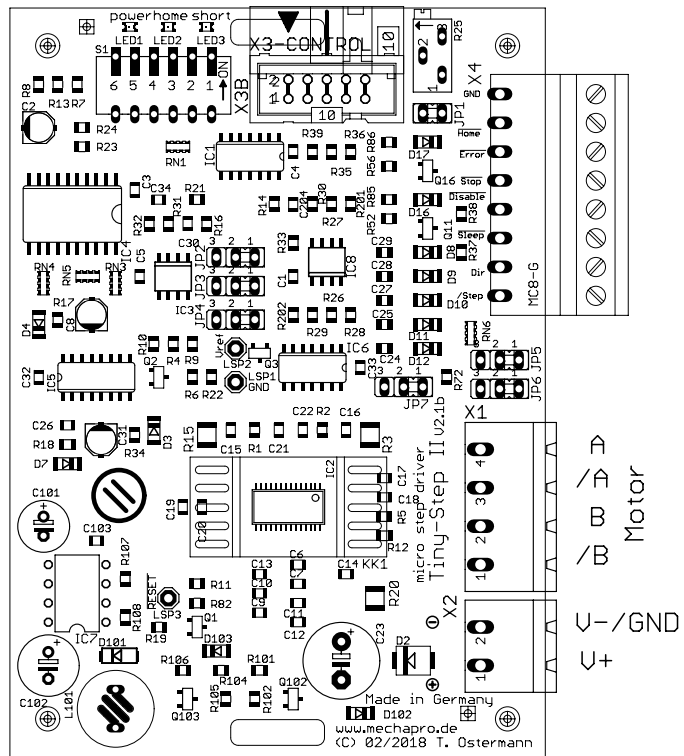

Default settings:

Resolution: 1/16 step
Current: 0,15 Apeak

X1 / Motor connector

| Pin no. | Function |
|---------|----------|
| Pin 4 | coil 1 |
| Pin 3 | coil /1 |
| Pin 2 | coil 2 |
| Pin 1 | coil /2 |

X2 / Supply voltage

| Pin no. | Signal | Function |
|---------|--------|----------------------------------|
| Pin 1 | V+ | positive supply voltage |
| Pin 2 | V- | negative supply voltage (ground) |

X3 / I/O Signals

| Pin no. | Function |
|----------|--|
| Pin 1 | not connected |
| Pin 2 | /Clock (Trigger on rising edge, non active signal on high) |
| Pin 3 | /Error (output, pulled low when short circuit is detected) |
| Pin 4 | Direction (Clockwise rotation on high) |
| Pin 5 | /Disable (pull to ground to disable the power bridge) |
| Pin 6 | /Current reduction (reduces the motor current when pulled low, depending on JP4) |
| Pin 7&8 | Input for +5V= logic supply |
| Pin 9&10 | 0V (GND) |

All I/Os are pulled up to +5V with internal pullups.

X4 I/O-Signals (plus version with DIN rail case only)

| Pin no. | Function |
|----------|---|
| Pin X4.1 | /Clock or analog speed set value (depending on JP5) |
| Pin X4.2 | Direction - Clockwise rotation on high |
| Pin X4.3 | /Current reduction - Reduces the motor current when pulled low (depending on JP3, JP4 and JP7) |
| Pin X4.4 | /Disable - Pull to ground to disable the power bridge |
| Pin X4.5 | /Stop - Disables the internal clock generator without disabling the power bridge |
| Pin X4.6 | /Error - Output, pulled low when short circuit is detected |
| Pin X4.7 | /Home – Output, pulled down to ground on each 4th full step. Signals the start of an electrical revolution. |
| Pin X4.8 | Signal ground (GND) |

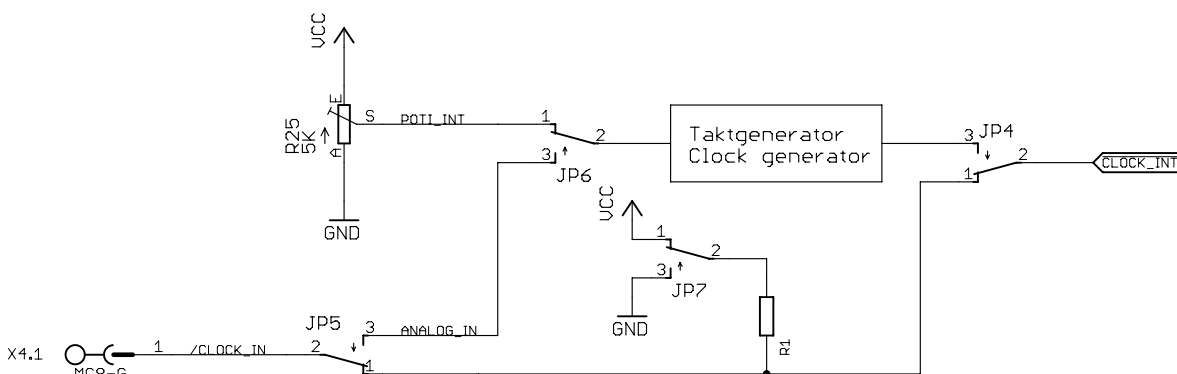

Block diagram: Selection of clock source

S1 / DIP switch

| Step width | S1.6 | S1.5 |
|------------|------|------|
| 1/1 | 1 | 1 |
| 1/2 | 1 | 0 |
| 1/4 | 0 | 1 |
| 1/16 | 0 | 0 |

| Current _{peak} | Current _{eff} | S1.4 | S1.3 | S1.2 | S1.1 |
|-------------------------|------------------------|------|------|------|------|
| 0.15A | 0.11A | 0 | 0 | 0 | 0 |
| 0.30A | 0.21A | 0 | 0 | 0 | 1 |
| 0.45A | 0.32A | 0 | 0 | 1 | 0 |
| 0.60A | 0.42A | 0 | 0 | 1 | 1 |
| 0.75A | 0.53A | 0 | 1 | 0 | 0 |
| 0.90A | 0.64A | 0 | 1 | 0 | 1 |
| 1.05A | 0.74A | 0 | 1 | 1 | 0 |
| 1.20A | 0.85A | 0 | 1 | 1 | 1 |
| 1.35A | 0.95A | 1 | 0 | 0 | 0 |
| 1.50A | 1.06A | 1 | 0 | 0 | 1 |
| 1.65A | 1.17A | 1 | 0 | 1 | 0 |
| 1.80A | 1.27A | 1 | 0 | 1 | 1 |
| 1.95A | 1.38A | 1 | 1 | 0 | 0 |
| 2.10A | 1.48A | 1 | 1 | 0 | 1 |
| 2.25A | 1.60A | 1 | 1 | 1 | 0 |
| 2.40A *) | 1.70A *) | 1 | 1 | 1 | 1 |

*) „plus“ version only!

Jumper

- JP1 Close to supply the logic from X3, leave open on models with internal voltage regulator (DIN rail version).
- JP2 Current reduction on logic high (pins 1-2, default) or at logic low (pins 2-3).
- JP3 Use automatic current reduction (pins 1-2, default) or input signal (Pins 2-3).
- JP4 Use /clock input signal (Pins 1-2, default) or internal clock generator (Pin 2-3) as motor clock signal.
- JP5 X3.2/X4.1 is input for clock signal (pins 1-2, default) or analog speed set value (pins 2-3)
- JP6 Speed set value for internal clock generator set by internal potentiometer (pins 1-2, default) or by analogue input value (pins 2-3).
- JP7 Input signals with pullup resistors (pins 1-2, default) or pulldown resistors (pins 2-3). If used on a controller with positive switching outputs (e.g. on a PLC) change setting to pulldown. In this case, the signals “/disable” and „stop“ must be driven high (logic 1) externally (e.g. by PLC) to activate the motor driver.

Potentiometer

R25 Speed setting for internal clock generator (plus version with DIN rail case only).

LEDs

LED1 +5V Logic supply present

LED2 Home is lit in every 4th fullstep position (=one electrical revolution)

LED3 Error, short circuit detected

Options / Variants

Apart from the standard version, the following version with extra features is available. Customer specific variants are available on request.

Version „plus“ for DIN rail mounting

Additional functions:

- With internal voltage regulator for 5V logic
- X1, X2, and X4 are equipped with pluggable cage clamps (Phoenix Combicon)
- Internal clock generator: outputs an adjustable clock frequency which makes it possible to move the motor continuously at a defined speed. Speed setting with internal potentiometer or analog set value.
- Delivered in plastic case to be mounted on DIN rails, width 22.5mm



Notes:

Dimensions:

