



All in one
stepper motor driver

Slider SFX

Control factory automation
machinery and
CNC machine tools
by use of stepper motors

The present stepper motor driver board was developed taking all common and established rules into account. It has undergone extremely thorough testing. Nevertheless, it is impossible to give a guarantee for completely fault-free operation. Furthermore, no responsibility can be accepted for damage caused as a result of using **Slider SFX**. The developers ensure that **Slider SFX** in combination with appropriate controls and appropriate mechanical components for the purpose of this description and manual is in principle appropriate for the intended use.

Each liability for associated consequential losses, such as loss of use, production and loss of profits is excluded. **Slider SFX** is a component that can only be used together with a power supply and an adequate control or control software on a personal computer. It is no independent control under any circumstances.

Despite the most strenuous efforts, it is never possible to completely eliminate all faults. Consequently, we would be grateful to receive feedback from users.

mechapro GmbH

Martin Luther Str. 3-5
52062 Aachen

Tel.: 0241/4091800

Fax: 0241/4091803

eMail : info@mechapro.de

January 2010

All products mentioned by name are trademarks or registered trademarks of their corresponding companies.

Table of content

1	What is Slider SFX used for?.....	4
1.1	Versions of Slider SFX	5
1.2	Optional 4th axis.....	6
2	Start of operation.....	7
2.1	Base settings on delivery	8
2.2	Mounting and ventilation.....	8
2.3	Mounting dimensions	9
2.4	X4 – Power supply	9
2.5	X10 – Control signals	10
2.6	JP1-JP8 – Jumper settings, signal assignment.....	11
2.7	JP6 – Pin14 drives relay 2 or PWM logic.....	12
2.8	JP10 – Toggle signal, safety function	12
2.9	JP11 – Start up time	13
2.10	JP12 – Invert relay signals.....	13
2.11	X3(1/2) – Emergency stop	13
2.12	X7 – Inputs for limit and reference switches	14
2.13	X2 – Switching outputs	14
2.14	X3(3/4) – Analogue output signal for spindle control.....	15
2.15	X6, X8, X11 – Motor connectors.....	16
2.16	X5 – Additional capacitor	17
2.17	S1/S2/S3/S5 – Setup of motor current and step width	17
2.18	LED's / status signals.....	18
2.15	X13 – Connector for external LED's	19
2.20	X1 – Fan connector	19
2.21	X9/X14 – Extension for 4th axis.....	20
3	Safety instructions.....	22

The structure of this manual...

This manual provides you with all information necessary to use your **Slider SFX**. It is divided into different chapters, the contents of which are summarised below:

Chapter 1: Short introduction and technical details

Chapter 2: Procedure for initial operation, pin out

Chapter 3: Safety instructions

1 What is Slider SFX used for?

The stepper motor driver **Slider SFX** is a sophisticated circuit, which includes power drivers for three or four 2-phase stepping motors and some other useful components. The signals to drive the board are connected to a 25-pin D-Sub type female connector, which can be driven by appropriate controls or directly by a LPT printer port of a personal computer with appropriate control software.

Slider SFX can be used ideally with the software products **PC-NC** and **WinPC-NC** that are also available on our shop. The signals are fully compatible to these control programs.

A three or four axes mechanic can be used for a wide range of applications. Some examples are....

- Engraving signs
- Milling 3D reliefs
- Milling negative matrices and casting moulds
- Cutting sticky foils
- Milling and drilling prototype PCBs
- Apply and dispense glues
- Cut and machine front plates
- Turning and shaping
- Gas and Plasma cutting
- Pick&Place or robot applications
- ...and many more

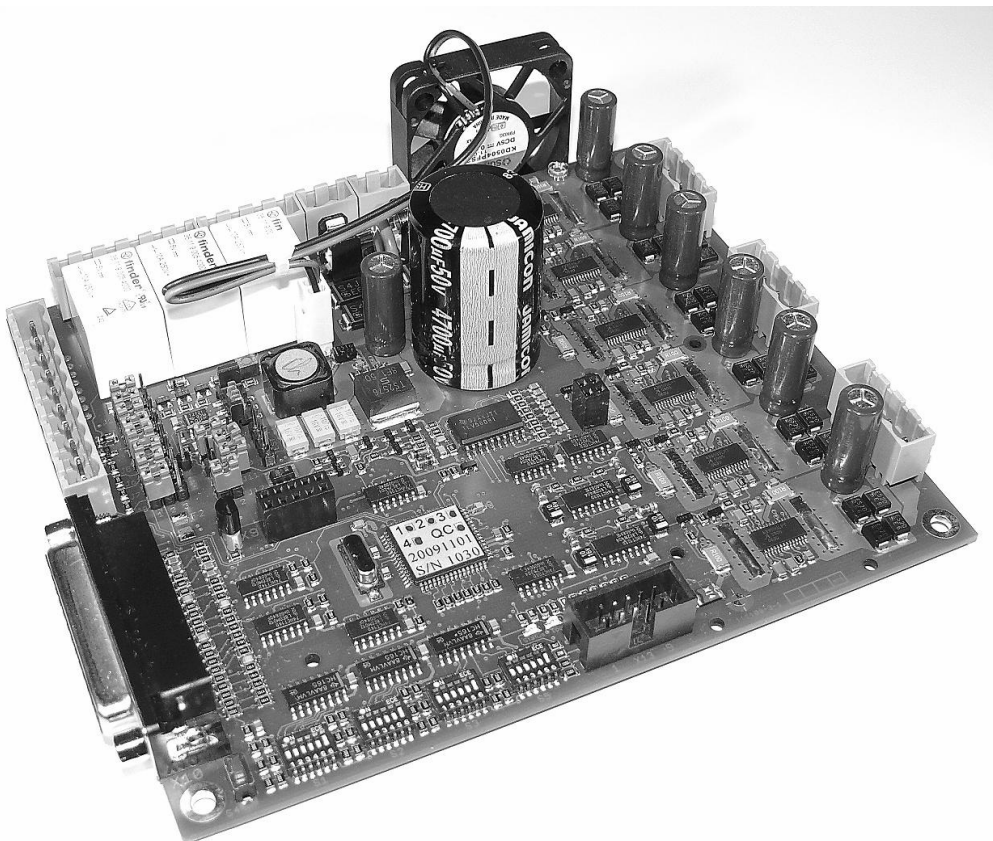

The technical data of the *Slider SFX* board are...

- Connection of three 2-phase stepping motors direct on the board
- Optional 4th axis as a plug-in board
- Single supply with AC or DC voltage without external stabilisation, meaning easy supply with a transformer
- Control signals via 25-pin D-Sub type connector (female), e.g. directly from a PC printer port (LPT)
- Full-, half-, quarter, 8th- to 16th-step, 2.5th to 10th-step also possible (sinusoidal micro step)
- Phase current up to 3.0A
- Individual setup of phase current for each axis with DIP switches, additional current reduction input (reducing current to 50%)
- Protected against short windings and shorts to ground
- Ready switch acts as enable signal directly to power stages and relays, can be used e.g. on a protection hood
- Three relays (240V~/10A) for switching outputs, e.g. main spindle, coolant pump, chuck etc., also capable of switching DC current
- LED's to signal supply voltage and other states, additional connector makes it possible to integrate LED's into front plate of housing etc.
- 5 free assignable inputs (N.O. or N.C. contacts), e.g. for limit or reference switches
- Protection circuit with toggle or ready signal to disable motors and relays
- Connector for additional 4th axis
- Standard version for ambient temperatures up to 50°C, special HT version for ambient temperatures of up to 70°C
- Analogue output 0-5V or 0-10V to drive speed controlled milling/drilling spindles, interpretation of a PWM signal
- Control of a relay depending on PWM value, threshold level 10%
- Emergency signal, N.C. contact
- Dimensions: 150*130*52mm

1.1 Versions of Slider SFX

The stepper motor driver *Slider SFX* is available in two versions and with optional 4th axis. The standard version is designed for ambient temperatures up to 50°C and has to be used

in housings and machines where this maximum temperature is not exceeded. A fan mounted to the side of the board or a case fan ensures proper cooling. A filter with 30 ppi or higher is required.

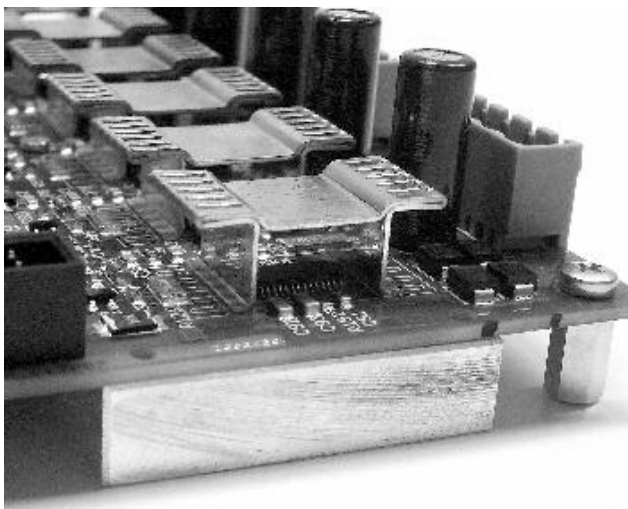

The version *Slider SFX HT* is designed for ambient temperatures up to 70°C and is equipped with passive heat sinks on both top and bottom side. A fan should be used in a similar way than on the standard version.

Although the drivers are protected by an excess temperature protection, proper cooling has to be clarified with the manufacturer.

Special fan less OEM versions or with other special and customer specific options can be supplied on demand. We are looking forward to your requests.

1.2 Optional 4th axis

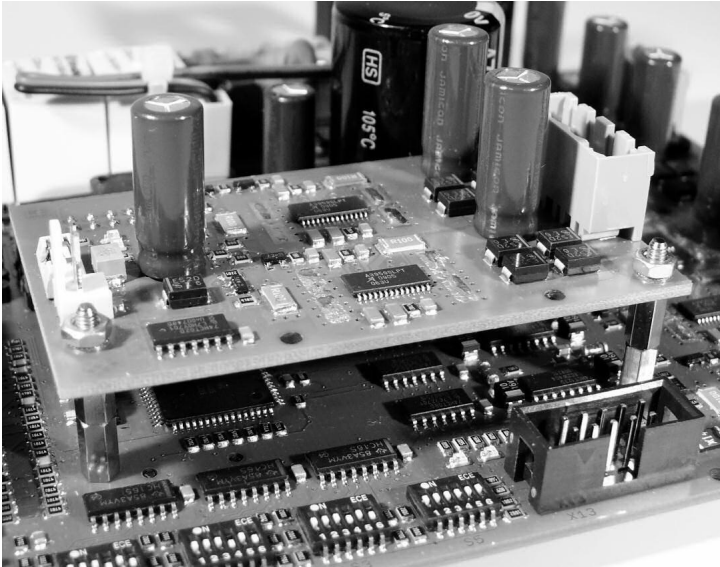

With an addon board, **SliderSFX** is capable of driving 4 axes. The plug-in position with two connectors and mounting holes is placed directly above the DIP switches.

The add-on module **SliderSFX-4** can be ordered together with the main board or later as a single part including mounting material. It can be easily installed by the user.

2 Start of operation

Please make sure to follow all protective regulations before the first initial operation of the board and before connecting or switching on the supply voltage.

On the **Slider SFX** board all connections are equipped with pluggable cage clamps. All connectors will be described in the following sections. The sketch gives a first overview. All relevant connections and settings are marked in grey.

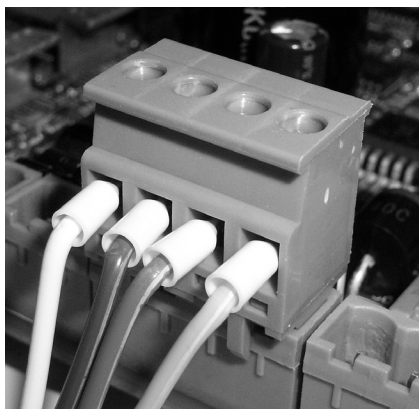
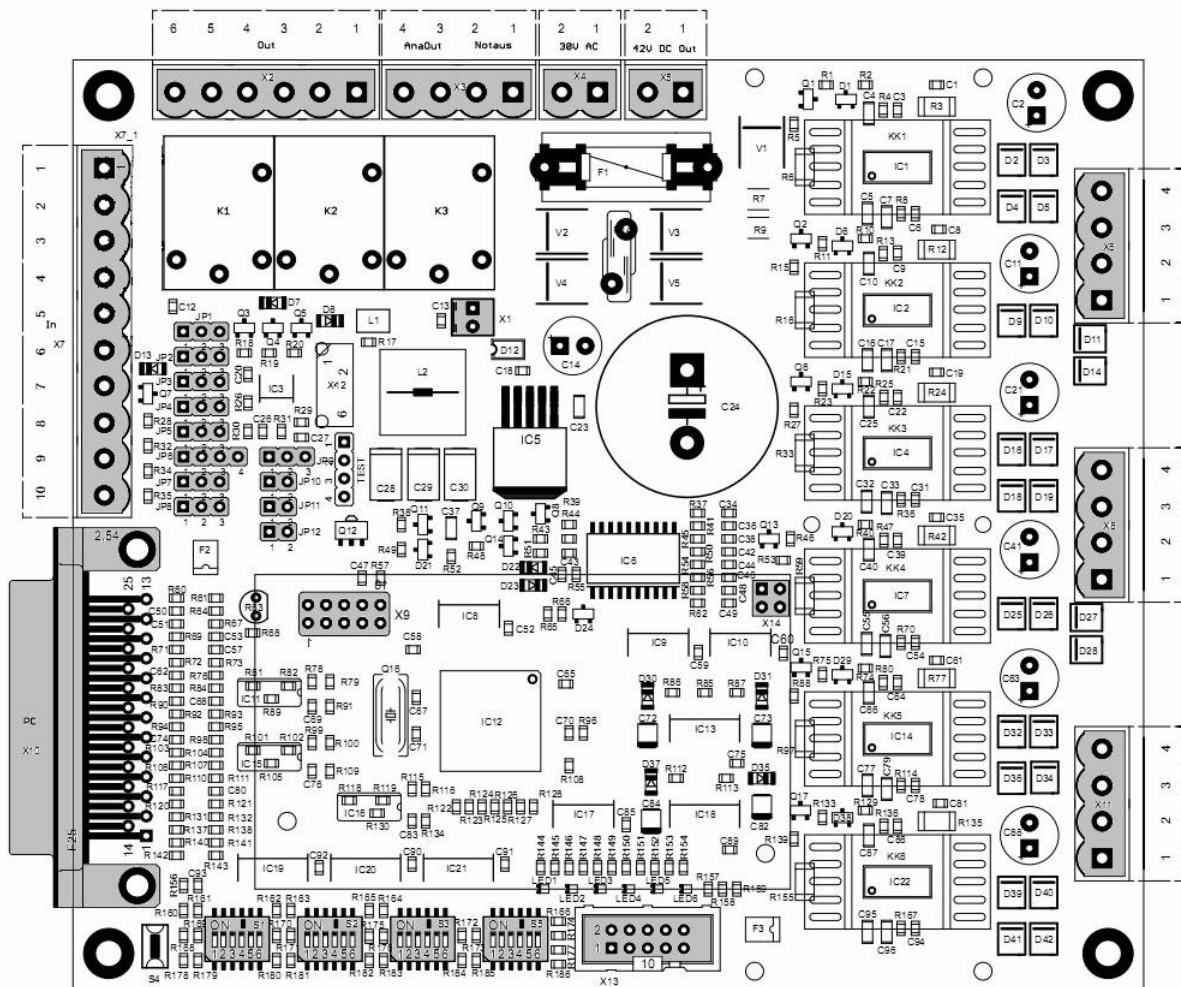

On all connections care should be taken to achieve the best possible contact. All signal and motor wires should be equipped with core cable ends. To avoid disturbances especially on the switch inputs on X7, shielded and/or twisted pair wires have to be used.

2.1 Base settings on delivery

The board is shipped in a base setting, where all jumpers are set to position 1-2 except for JP10. This results in the following functional assignment on the interface X10 (input from the parallel port of a PC):

Pin 14 switches relay 2

Pin 15 is general input

Pin 16 switches relay 3

Pin 17 controls the current reduction of the motors (low active)

For a complete description of the interface X10 please refer to section 2.5.

The voltage range on the analogue output (to control a main spindle) is set to 0-10V. The monitoring of the toggle signal is disabled. Relays are not inverted and the start up time is approx. 3 seconds.

The DIP switches are set in a way that all motors are driven with 1.0A and in quarter step mode, meaning with 800 steps/rev for a standard 1.8° motor.

2.2 Mounting and ventilation

Slider SFX is tested for ambient temperatures of up to 50°C. An **HT** version is available for ambient temperatures of up to 70°C. When mounting the board into a case, sufficient ventilation has to be provided, e.g. by placing adequate ventilation slots in the case hood. The fan that is mounted on the side of the **Slider SFX** board can be used on both sides of the board, according to assembly and ventilation in the case. If a case with integrated fan is used, the air stream should pass the 6 drivers (IC's 1, 2, 5, 7, 12 and 17). The direction of the board's fan air stream should be adjusted in the same direction as the case fan. If the ventilation of the case is sufficient, the fan on the board might be redundant.

Warning:

Ventilations slots (for active or passive cooling) should be covered with filter pads of at least 30 ppi to protect them against intrusion of chips. Intruding chips and metal parts can influence the function of the board and may also completely destroy it!

The **HT** version for ambient temperatures up to 70°C is equipped with a 10mm thick aluminium heat sink on the bottom side. This heat sink has to be mounted to the bottom plate of the case with its full surface. This ensures optimal heat conduction.

2.3 Mounting dimensions

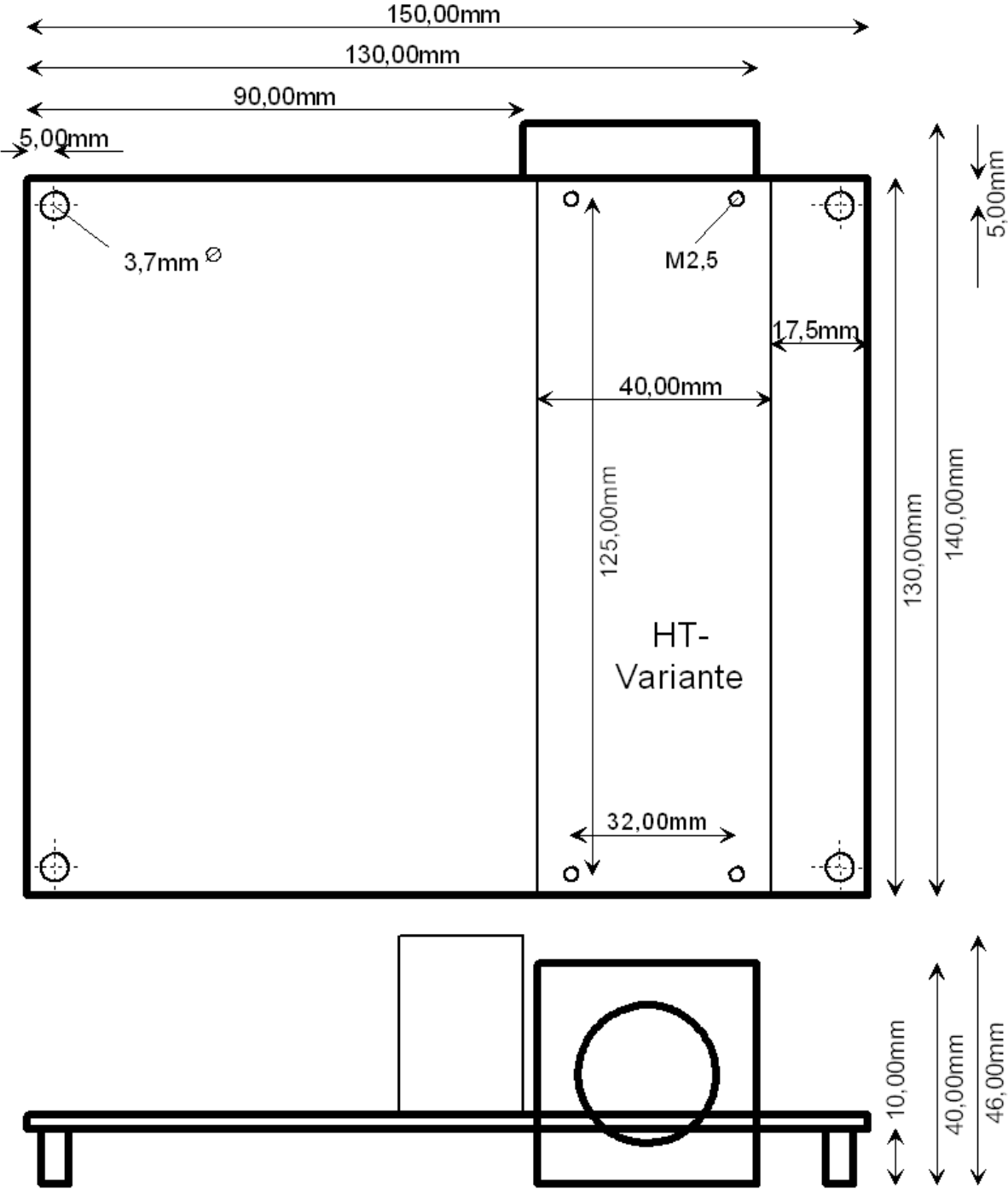

2.4 X4 – Power supply

The stepper motor board **Slider SFX** can be supplied with either AC or DC voltage. When using DC power, the lower threshold is 12V~ while the upper threshold is 30V~. For DC power the thresholds are 15V= and 42V=, the polarity is irrelevant. The supply input is protected by a glass fuse (6.3A fast blow). Blown fuses must always be replaced by the same rated current and characteristic!

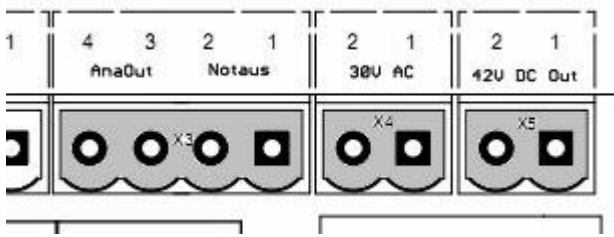

We recommend a transformer or power supply rating of 100VA to 160VA, depending on the employed motors and the voltage level of the supply. We would be happy to give you an advice. To follow the EMC regulations an adequate supply filter has to be used in addition the transformer used in your application.

Attention:

When decelerating a stepper motor acts as a generator. This causes the supply voltage to increase. The voltage should not exceed 45V= to avoid damaging the drivers. This danger is more likely with higher supply voltages.

2.5 X10 – Control signals

All control signals are feed in by the 25-pin female D-Sub type connector. The signals are switched to ground and are designed in a way that also weak ports on modern computers are able to drive them.

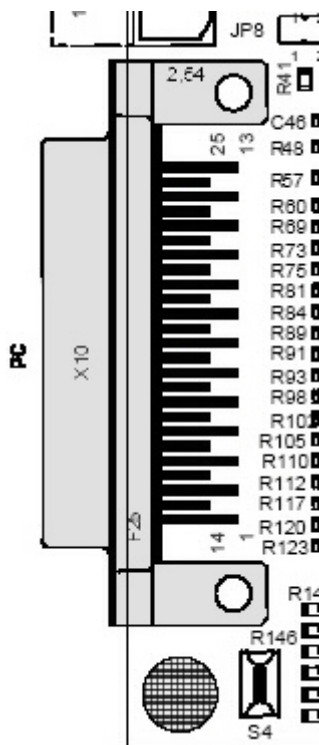

The pin out is...

- Pin 1 Relay 1, e.g. main spindle on/off
- Pin 2 Direction motor X
- Pin 3 Clock motor X
- Pin 4 Direction motor Y
- Pin 5 Clock motor Y
- Pin 6 Direction motor Z
- Pin 7 Clock motor Z
- Pin 8 Direction motor 4 (option) or relay 2
- Pin 9 Clock motor 4 (option) or relay 3
- Pin 10-13 Forwarded inputs, e.g. for signals from limit and reference switches
- Pin 14 PWM signal or relay 2, e.g. coolant pump on/off
- Pin 15 Output for ready signal or signal from limit or reference switches
- Pin 16 Toggle signal or relay 3, e.g. chuck for tool changer
- Pin 17 Current reduction input (active low), toggle or PWM signal
- Pin 18-25 Signal ground (0V, GND)

Together with our CNC control software **PC-NC CNC-Control**, **WinPCNC** and **X4Step** there are no compatibility problems driving a 3 or 4 axes mechanic. Of course any other software with pulse and direction output signals can be used.

2.6 JP1-JP8 – Jumper settings, signal assignment

Some pins (8, 9, 14, 16 and 17) on **Slider SFX** can be used for different functions. Section 2.4 gives an overview about all inputs and their functions. The settings are made with jumpers, while setting connection pins 1-2 is the standard setting (except for JP10).

- JP1: Pin15 forwards general input (jumper 1-2) or outputs ready signal (low active) of **Slider SFX** (jumper 2-3).
- JP4: Pin16 switches relay 3 (jumper 1-2) or drives toggle signal (jumper 2-3).
- JP6: Pin14 switches relay 2 (jumper 1-2) and/or drives PWM signal (jumper 3-4). To use both functions, two jumpers are necessary.
- JP7: Pin8 switches direction of motor 4 (jumper 1-2) or switches relay 2 (jumper 2-3).
- JP8: Pin9 switches clock of motor 4 (jumper 1-2) or switches relay 3 (jumper 2-3).

To evaluate the ready signal with **WinPCNC** the signal "I247 NReady" has to be assigned to Pin15.

The ready signal is disabled (meaning set to logic high) by **Slider SFX** when the contact X4 (emergency switch) is opened or when an error occurs on the board (e.g. shorted coil of a motor). With this signal it can be avoided that the board continues operation after clearing an error, although the position of the motors doesn't comply with the position that is assumed by the CNC software.

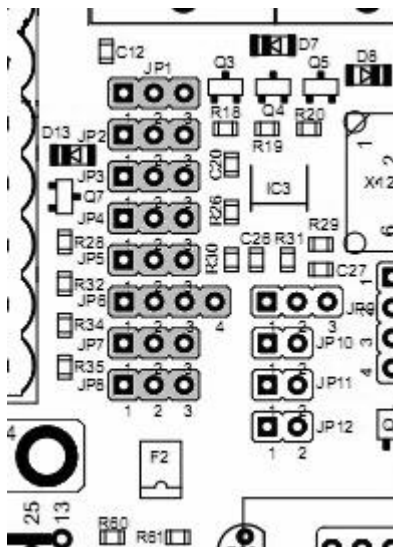

Caution:

Never configure two pins for the same function, as this may result in a short of the outputs on the printer port. This concerns all jumper settings from JP2 to JP8.

To avoid damages by unintended touching of nearby components, it is highly recommended to change jumper settings only when the board is powered down.

Function of Pin17	JP2	JP3	JP5
Current reduction	1-2	1-2	Any
Toggle	2-3	2-3	1-2
PWM	2-3	2-3	2-3

When using **WinPCNC** with the current reduction signal on Pin17, Signal "Q251 axis running" has to be set to "Pin 17 inverted".

2.7 JP6 – Pin14 drives relay 2 or PWM logic

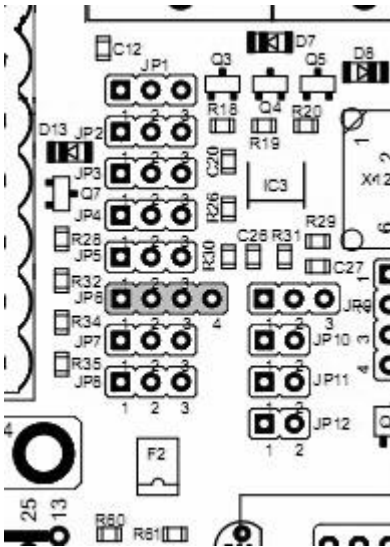

Jumper JP6 is intended as a double contact and selects two functions.

If set to position 3-4, the signal coming from Pin14 is fed to the PWM logic and converted to an analogue signal with 0-5V or 0-10V range. If a jumper is set to position 1-2, Pin14 controls relay 2. When both jumpers are set, Pin14 is fed to the PWM logic and relay 2 is switched automatically depending on the PWM value.

The threshold includes a hysteresis of approx. 5%. At PWM values higher than 10%, the relay is switched on. When the PWM value falls under 5%, the relay is switched off again.

- Jumper JP6 set to 1-2 only Pin 14 controls relay 2
- Jumper JP6 set to 3-4 only Pin 14 controls PWM logic which outputs the analogue value
- Jumper JP6 set to both 1-2 and 3-4 Pin 14 controls PWM logic and relay 2 is switched depending on PWM value.

2.8 JP10 – Toggle signal, safety function

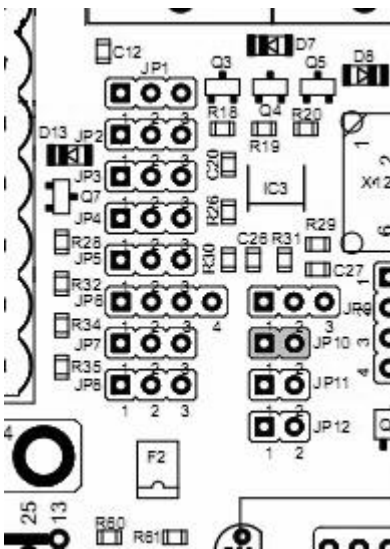

On power up and caused by plug&play routines of the operating system, the pins on the parallel port may change their logic levels before the port is under control of the CNC software (e.g. **WinPCNC**). To prevent unintended switching of relays and unintended movements of the motors, **WinPCNC** supports the output of a safety signal (" Q219 Toggle/ Ready"). In other products this is sometimes referred to as " charge pump signal" . If enabled, **Slider SFX** will enable relays and motors only when a valid toggle signal (minimum frequency of 250 Hz) is recognised.

When using a control software that doesn't support this signal, e.g. **PCNC** (DOS), the monitoring of this signal has to be disabled by setting JP10 to position 2-3 (default setting).

- JP10: Toggle signal monitored (Jumper 1-2) or not (Jumper 2-3).

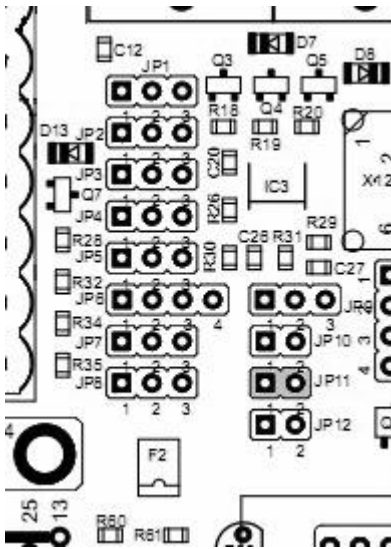

2.9 JP11 – Start up time

Jumper JP11 influences the start up time of the board. When the jumper is left open, it takes approx. 3 seconds after power on until the board is ready and the motors are under current. With JP11 set, this time is extended to approx. 10 seconds. This may help to ensure, that the primary control or the PC with control software is ready and all signals are in a defined condition.

On each boot up, the board signals the version number of the firmware on LED1, before ready is indicated.

- JP11: Start up time 3 seconds (jumper open) or 10 seconds (jumper closed)

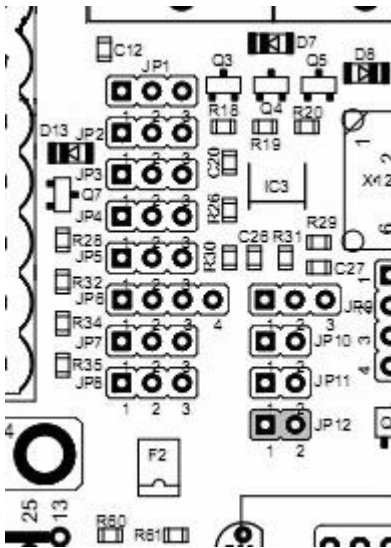

2.10 JP12 – Invert relay signals

Depending on the signal level to control the relays, it may be, that the behaviour of the relays is inverted compared to the driving logic. Additionally, during power on or boot up of the PC the relays may be switched unintended. With JP12 closed, the control signals for all three relays are inverted.

- JP 12: Relay control signals inverted (jumper closed) or normal (jumper open).

2.11 X3(1/2) – Emergency stop

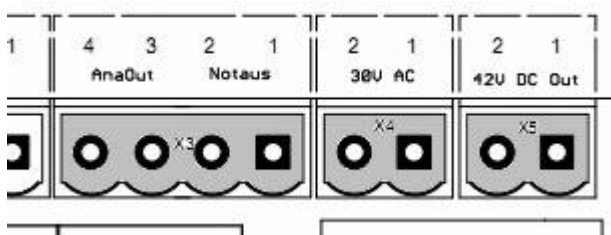

The ready or emergency signal on clamp X3, contacts 1/2, activates the three power drivers for the motors and also acts as enable signal for the relays. The signal is routed to the enable input of the power drivers and can therefore be used as an emergency signal or as a contact of a protection hood.

The switch has to be an N.C. contact. With the contact opened, all three motors are current less and can not be driven by the board. Same applies for the relays.

Caution:

Current less motors do have a very small holding torque. If they are in motion, they continue running due to the inertia of the axis. A current less Z-axis may fall down on the table or to the mechanical limit due to its mass.

If no switch is used, the contact must be closed by a wire strap to ensure proper operation of the board.

Pin out on X3:

Pin 1 Emergency contact
 Pin 2 GND

2.12 X7 – Inputs for limit and reference switches

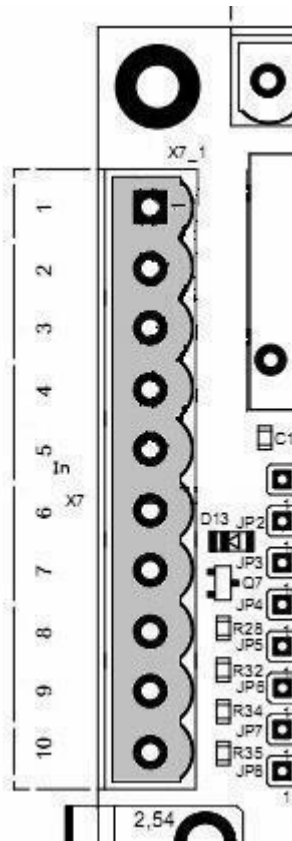

The stepper motor board **Slider SFX** has 5 inputs that are forwarded to signals on the 25 pin D-Sub type connector. These are exactly the signals, which are used as inputs on the PC parallel port. Switches with both N.O. or N.C. can be used. For each input, two cage clamp contacts are present.

The pin out is as follows...

- Clamp X7.1 Pin 10
- Clamp X7.2 GND
- Clamp X7.3 Pin 11
- Clamp X7.4 GND
- Clamp X7.5 Pin 12
- Clamp X7.6 GND
- Clamp X7.7 Pin 13
- Clamp X7.8 GND
- Clamp X7.9 Pin 15
- Clamp X7.10 GND

Depending on the interpretation in the control or in the control software, these inputs can be used for limit switches, reference switches or other sensors.

Please note:

Depending on setting of JP1, Pin 15 forwards input X7.9 or signals the operational status of the boards

2.13 X2 – Switching outputs

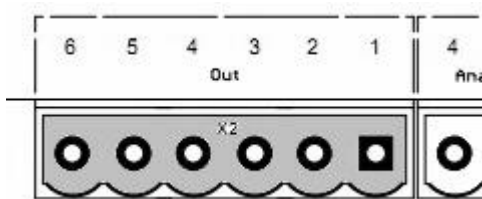

Slider SFX is equipped with 3 relays which are controlled over the 25-pin D-Sub type port. Depending on the configuration of the board, the pins 1, 8, 9, 14 and 16 are possible inputs, which can be controlled by **PCNC** or **WinPCNC** as outputs for main spindle, coolant pump and chuck for tool changer or other purposes.

The assignment between pins and relays is done with jumpers (see chapter 2.5).

The assignment is as follows...

- Clamp X2.1/2 relay 1 - pin 1
- Clamp X2.3/4 relay 2 - pin 14 (alternative pin 8)
- Clamp X2.5/6 relay 3 - pin 16 (alternative pin 9)

All relays can switch up to 10A at max. 240VAC. DC currents can be switched also.

2.14 X3(3/4) – Analogue output signal for spindle control

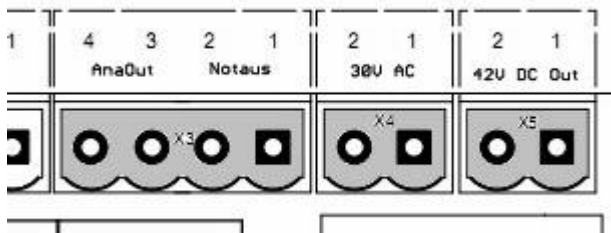

Slider SFX can convert a PWM input signal (min. PWM frequency 200 Hz) to an analogue output signal. Many frequency converters accept such a signal as reference value for the rotational speed of synchronous or asynchronous main spindle motors. Consult the manual of your converter to see how the reference input has to be parameterised.

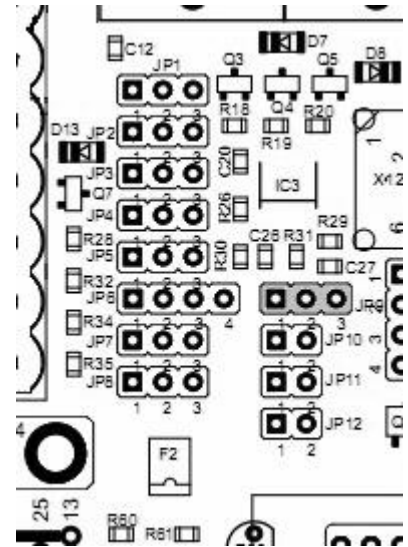

The output of **Slider SFX** supports either a signal range from 0V to 10V (default setting) or from 0V to 5V, where 10V (or 5V respectively) equals the maximum rotational speed. Pre-condition to use this feature is to select an input pin for the PWM signal and a matching configuration of the control software, e.g. our **Win-PCNC** (signal "Q218 rotational speed PWM").

The PWM signal can be evaluated from pin 14 or pin 17. The mapping of the signals is done by jumpers JP2, JP3, JP5 and JP6.

- JP9: analogue output (main spindle) 0-10V (jumper 1-2) or 0-5V (jumper 2-3).

2.15 X6, X8, X11 – Motor connectors

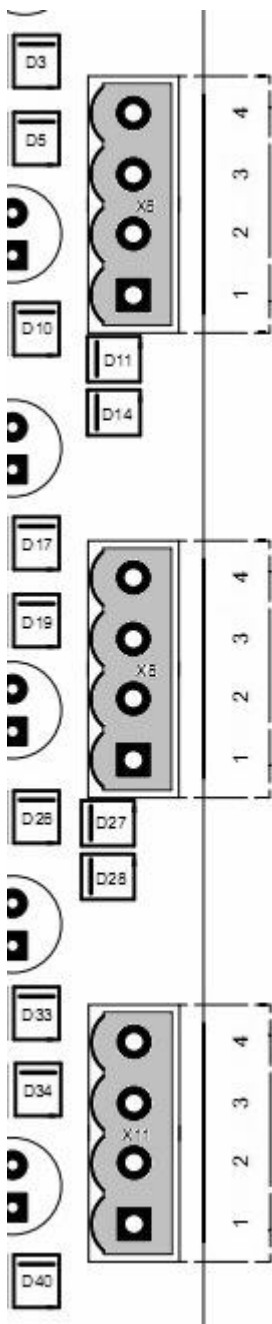

Slider SFX is designed for 2-phase stepping motors only. It can be used with both bipolar and unipolar motors. If no datasheet is available to your motors, you have measure which connectors belong to which winding of the motor.

Bipolar motors have 4 connections, where each winding has two connections. These can be found easily with an Ohm meter. Both ends of one winding have to be connected to the board as phase A1/A2, while the other one are connected as phase B1/B2.

Unipolar motors come with 5 or 6 connections, where both windings have an additional contact in the middle of the coil. Also with this motors, the endings of whe coils can be found easily by measuring the resistance of the different connections. Leave the centre taps unconnected and isolate them to prevent any contact with conductive materials. The connection to the board is then the same as before, connecting one coil to phase A1/A2, the other one to phase B1/B2.

When the motor connections are correct, the motors should move smooth and without jerk in both directions. A wrong connection leads to jerky movement or in a dithering movement of the motor.

The direction of the motor's movement can be changed by crossing the connections on one of the phases, e.g. changing A1 with A2.

The connections are assigned as follows:

- X11 (1+2) – X axis phase A
- X11 (3+4) – X axis phase B
- X8 (1+2) – Y axis phase A
- X8 (3+4) – Y axis phase B
- X6 (1+2) – Z axis phase A
- X6 (3+4) – Z axis phase B

Attention:

Do not connect a motor phase to positive supply voltage under no circumstances. This would inevitably lead to a break down of the power driver.

2.16 X5 – Additional capacitor

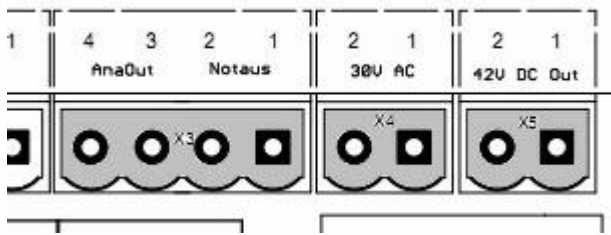

When decelerating, a stepper motor acts as a generator and supplies current back to the power supply. This will temporarily cause the supply voltage to increase significantly. To prevent rising above 45VDC, an electrolytic capacitor can be connected to clamp X5 in addition to the capacitor in the power supply.

Especially when using large and powerfull motors and high supply voltages, an additional capacitor is recommended.

Assignment on X5:

Pin 1 GND
Pin 2 +42V

Please note:

In most circumstances, the use of an additional, external capacitor is not necessary.

2.17 S1/S2/S3/S5 – Setup of motor current and step width

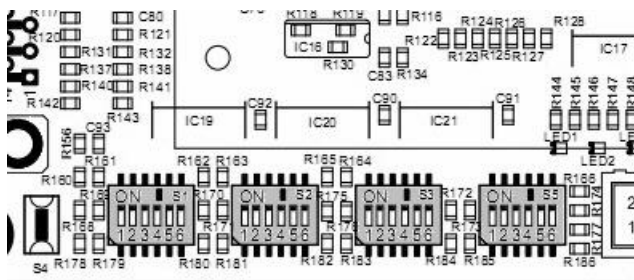

The stepping motor drivers support microstep operation. They produce a sinusoidal course of motor currents. The step width can be set individually for each motor with the left three DIP switches according to the following table.

Beside the dividers that are common for 2-phase motors down to 1/16th (3,200 steps per revolution) it is also possible to use dividers 1/2.5th to 1/10th commonly used with 5-phase motors (500, 1,000 and 2,000 steps per rev.).

Furthermore the right three DIP switches are used to set the phase current of the power drivers in 0.25A steps. In addition, pin 17 can be used to activate a current reduction down to 50% of the selected set value. See section 2.5 for details. If clock pulses are applied to the board with current reduction activated, the onboard controller will automatically disable the current reduction until all steps are processed.

Changes on the DIP switches are taken over within less than 1 second without rebooting the board. Changes to the step width may result in a position error of up to 4 full steps, so it is recommended to do a reference movement after changing this setting.

The axes are allocated to the switches as follows:

- S1 – X axis
- S2 – Y axis
- S3 – Z axis
- S5 – optional 4th axis

For each axis (n=1, 2, 3, 4) there exist 6 DIP switches. The switches Sn.1-n.3 are used for setting the set value for the motor current, while the switches Sn.4-n.6 define the step width according to the following tables:

Sn.1	Sn.2	Sn.3	Current
0	0	0	1.0 A (default setting)
0	0	1	1.5 A
0	1	0	1.75 A
0	1	1	2.0 A
1	0	0	2.25 A
1	0	1	2.5 A
1	1	0	2.75 A
1	1	1	3.0 A

Sn.4	Sn.5	Sn.6	Step width
0	0	0	$\frac{1}{2}$
0	0	1	$\frac{1}{4}$ (default setting)
0	1	0	$\frac{1}{8}$
0	1	1	$\frac{1}{16}$
1	0	0	$\frac{1}{1}$
1	0	1	$\frac{1}{2,5}$
1	1	0	$\frac{1}{5}$
1	1	1	$\frac{1}{10}$

2.18 LED's / status signals

There are some LED's placed above the connector X13, that are used to signal the current operating condition of the **Slider SFX** board.

- LED1: Status indication
- LED2: Short detected, the blink code identifies the faulty axis
- LED3: Toggle signal (safety function) recognised
- LED4: Shutdown due to over voltage
- LED5: Power supply present
- LED6: 5V (Logic supply) present

Explanation to the meaning of the LED's:

LED1 signals errors on the board. A continuous, slow blinking LED signals that contact X4 was opened. A fast, 4-times blinking with following pause signals a short condition on one of the outputs.

LED2 shows, if a valid toggle signal was detected. If the evaluation of the toggle signal is activated (JP10 set to 1-2), and LED7 is not lit (meaning no valid signal is applied to the board), the drivers are switched of and the board is not ready.

LED3 signals a short on one of the axes and has to be cleared by the reset button S4. LED3 blinks once for a short on the X axis, twice for a short on the Y axis, three times for a short on the Z axis. The blink code will be repeated after a short pause. For a fault on the optional 4th axis, LED3 is lit continuously.

If the supply voltage rises above 44V, the power supply shuts down the logic voltage (5VDC), which leads to a shut down of the power stages. This is signalled by LED4.

2.15 X13 – Connector for external LED's

If **Slider SFX** is mounted into a case, so that the on board LED's can not be seen from the outside, it is possible to connect some additional LED's to connector X13, which then can be mounted into the front plate of the case. The pinout of X13 is:

Pin 1	LED1, Status (Vcc)
Pin 2	VMotor (used for LED5)
Pin 3	LED4, over voltage (VMotor)
Pin 4	(not used)
Pin 5	LED5, motor supply voltage (GND)
Pin 6	LED3, short detected (Vcc)
Pin 7	LED6, VCC (GND)
Pin 8	LED7, Toggle (GND)
Pin 9	GND
Pin 10	VCC/+5VDC

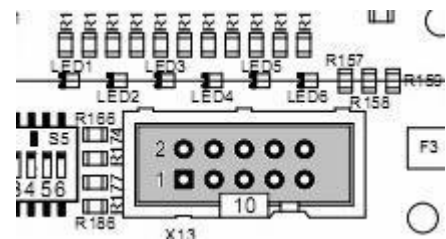

With except to LED 1, 3 and 4, all LEDs are connected to ground. LEDs 1 and LEDs 3 is connected to VCC/+5VDC, while LED4 is connected to VMotor.

2.20 X1 – Fan connector

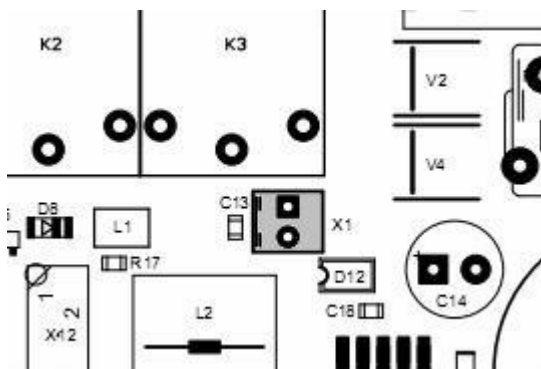

On the connector X1 5VDC are supplied for the fan mounted to the side of the board. This fan can be mounted on the upper or lower side of **Slider SFX**, depending on mounting situation and ventilation in the case. If a case with integrated fan is used, the air stream should pass the 6 drivers (IC's 1, 2, 5, 7, 12 and 17). The direction of the board's fan air stream should be adjusted in the same direction as the case fan. In this case the fan mounted to the board may be redundant.

2.21 X9/X14 – Extension for 4th axis

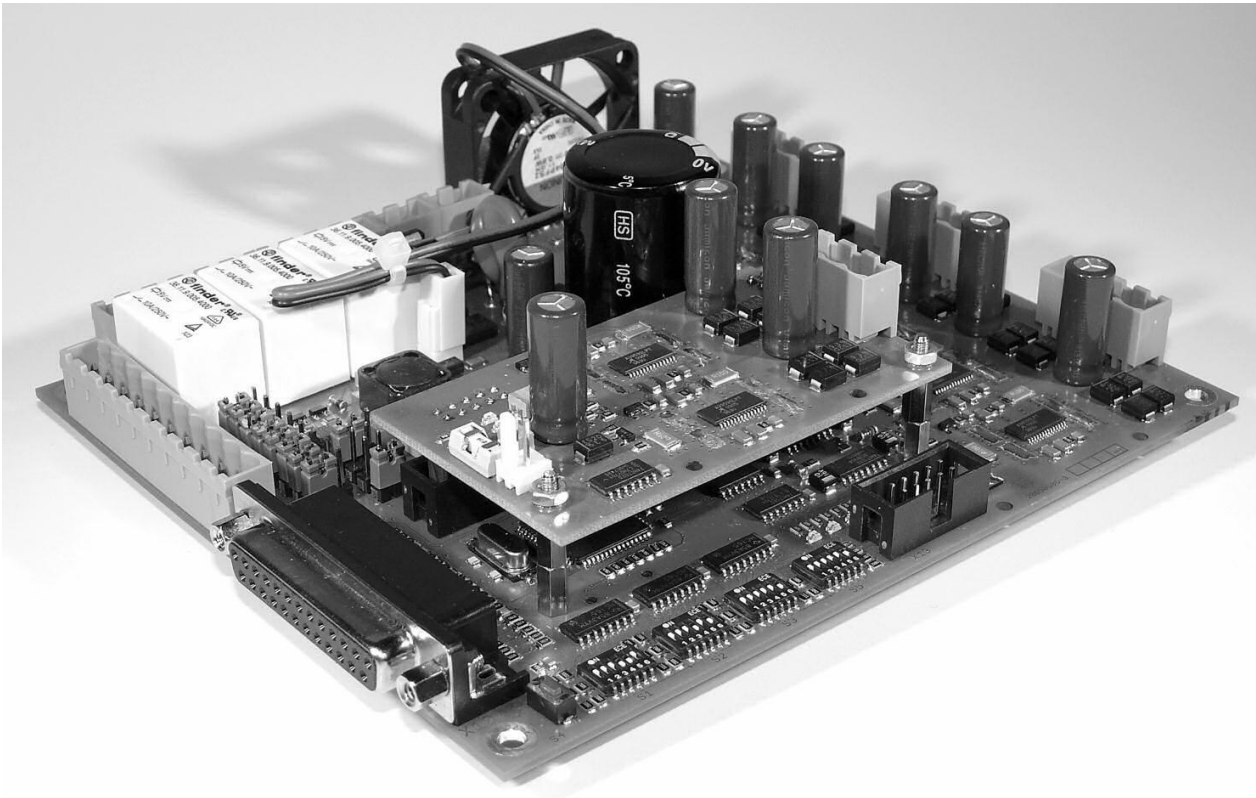

To upgrade **Slider SFX** to a 4 axes driver, connectors X9 and X14 provides the necessary control signals. The upgrade is done with a small add on board, that includes all components including the connector for the 4th motor.

Please follow these instructions when mounting the add on board:

- Mount distance bolts with retaining washers
- Torque the bolts with a 4mm socket wrench
- Plug in the add on board
- Screw the board with screws and retaining washers

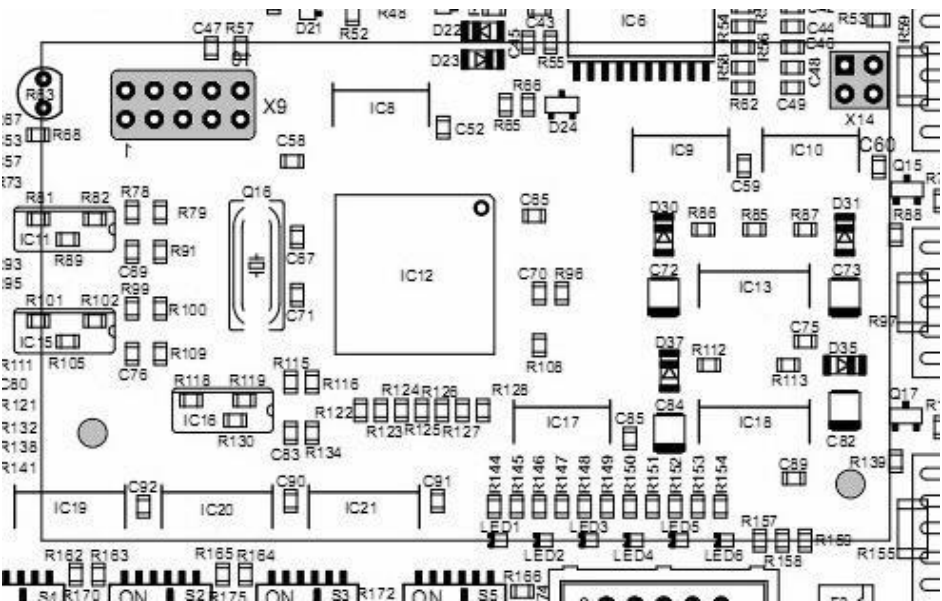

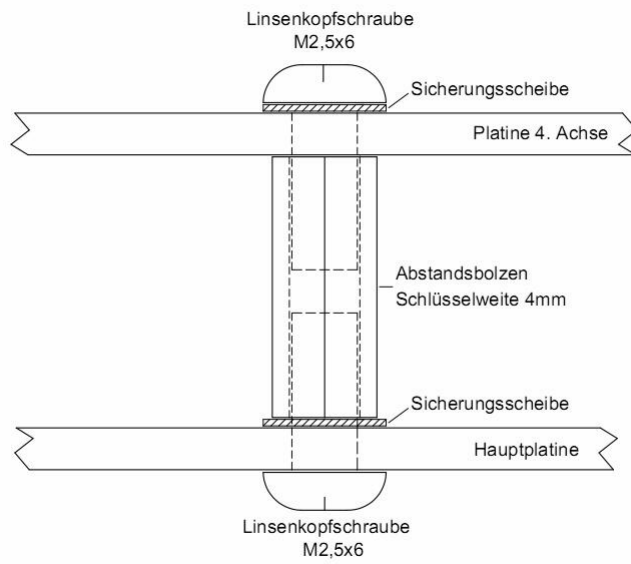

3 Safety instructions

The stepper motor driver **Slider SFX** is partially exposed to high thermal and mechanical loads. All modifications and changes to the board are done on the risk of the user and lead to loss of all warranty and guaranty claims.

If the board is mounted into a case, this case must have an active cooling (e.g. a fan). The heat conducting components reach temperatures of 70°C and above during normal operations.

The user has to make sure that all legal regulations (e.g. VDE, CE, EMC) are observed. Especially when connecting the supply voltage caution has to be exercised. Provide an emergency switch under all conditions and use it to disable the drives.

Use separate and shielded wires for connection of motors and limit/reference switches. For the motor wires we recommend to use wires of diameter AWG24 (0.25mm²) or better. All wires should not exceed a length of 3 meter.

Notes:

Connectors, switches and jumpers at a glance

Dimensions: 150*130mm

Moting hole distances: 140*120mm

