

Documentation for Stepper motor driver HEM-545 last change: 27.5.2010



Functional description

HEM-545 is a one channel motor driver for 2-phase stepping motors with pulse and direction interface. Motor step size can be set to microstep resolutions down to 1/16th step. The motor output is protected against short circuit. The "mixed decay" current control reduces current noise in the motor coils, which leads to quieter motor movement and higher dynamic in the upper speed range. Thanks to the application of a modern driver stage with low power loss, a separate heat sink is not necessary. The unit can be mounted horizontally or vertically with the designated mounting holes. The device can be supplied with different options. Customer specific add-ons are taken into account during development. We are looking forward to you requests.

Technical data

Supply voltage: 15-45V=

Motor current: adjustable from 2.0 to 5.0A (peak)

Max. current consumption: 3A

Motor outputs: Short circuit protected

Signal inputs and outputs supplied with optocouplers (galvanic isolation)

Contact information

mechapro GmbH

Martin-Luther-Str. 3-5 • D-52062 Aachen

Phone.: +49/241/4091800 • Fax: +49/241/4091803

Mail: info@mechapro.de • Web: www.mechapro.de

Exclusion of Liability, EMC (electromagnetic compatibility)

Even though all parts of the circuitry have been thoroughly checked and tested, mechapro does not give any warranty or other assurance as to the operation or functionality of the circuitry or the documentation.

To the full extent permissible by law we disclaim all responsibility for any damages or losses (including, without limitation, financial loss, damages for loss in business projects, loss of profits or other consequential losses) arising from the use and/or operation of the presented circuitry.

The stepping motor driver "HEM-545" is an OEM product made for use in industry, electronic trade and other EMC experienced sectors. According to EMVG §5, section 5 this product does not require CE qualification.

Cabling, used amplifiers, power supply, housing and the surrounding environment are factors that influence the EMC properties of a device. A device using one or more step motor drivers must of course be evaluated according to corresponding directives, when CE conformity must be documented. During development all possible means were used to conform to EMC regulations.

Initial operation

Before using the driver, set the DIP switches to the desired settings according to following descriptions. Afterwards the driver can be mounted in a case or cabinet and get wired to the machine and the controller or interface. When all connections are done, the unit is ready to operate.

Default settings

Step width: 1/16th micro step
Current: 2.0A peak
Current reduction set by input X4.3/X4.4

Connections

The following section gives a brief overview on the functions of the different connectors. Afterwards, the pin outs of the multipolar connectors are given in detail.

- X1 is the connector for the supply voltage. 12V to 45V DC are accepted. Take care of the polarity! Case ground (protective earth) is coupled to ground (V-) by a capacitor.
- X2 is the connector for the motor coils.
- Connector X3 carries the logic output signals „/error“ and „/home“ . On devices with option brake, the brake is connected to the „/home“ output. See section brake for details.
- Connector X4 is used for the logic input signals „ pulse“ , „ dir“ , „/current reduction“ and „ enable“ . On devices with options, some signals may have different functions. Follow the instructions in the options section.
- The DIP switch S1 is used to set the motor current, microstep resolution and enables the automatic current reduction when no clock pulsed are applied to the driver.

X1 / Supply voltage

Pin no.	Signal	Function
Pin 1	PE	Case ground, connect with PE
Pin 2	V-	negative supply voltage (ground)
Pin 3	V+	positive supply voltage

X2 / Motor connector

Pin no.	Function
Pin 1	winding A
Pin 2	winding /A
Pin 3	winding B
Pin 4	winding /B

X3 / Output signals

Pin no.	Function
Pin 1	/error (collector)
Pin 2	/error (emitter, single ended systems: connect to signal ground)
Pin 3	/home (collector)
Pin 4	/home (emitter, single ended systems: connect to signal ground)

/error is active (pulled down) when the driver is switched off as a reaction of an error (e.g. overtemperature, short circuit). To reset the driver, the enable signal has to be set back and activated again or the driver has to be restarted by disconnecting the power source.

/home is active (pulled down) on each 4th full step position, meaning after each electrical revolution of the motor.

X4 / Input signals

Pin no.	Function
Pin 1	enable+
Pin 2	enable-

The driver is active, when currents flow to the input.

Pin 3	/current reduction+
Pin 4	/current reduction-

The current reduction is active, when no currents flow to the input.

Pin 5	dir+ (direction of movement)
Pin 6	dir-

The motor turns in CCW direction, when currents flow to the input.

Pin 7	pulse+
Pin 8	pulse-

A rising flank of the signal (inactive to active) triggers the input and causes the motor to make a step.

S1 / DIP switches

Schrittweite	S1.3	S1.2	S1.1
1/1	0	1	1
1/2	0	1	0
1/4	0	0	1
1/8	1	0	0
1/16	0	0	0

S1.4: „0“ – Current reduction is activated by the input (X4.3/X4.4).

„1“ – The current reduction is activated automatically approx. 1 second after the last pulse has been processed.

In both modes, the current is reduced to 50% of the nominal current, but at least to 2A(peak).

Strompeak	Stromeff	S1.8	S1.7	S1.6	S1.5
2,0A	1,40A	0	0	0	0
2,2A	1,55A	0	0	0	1
2,4A	1,70A	0	0	1	0
2,6A	1,85A	0	0	1	1
2,8A	2,00A	0	1	0	0
3,0A	2,10A	0	1	0	1
3,2A	2,25A	0	1	1	0
3,4A	2,40A	0	1	1	1
3,6A	2,55A	1	0	0	0
3,8A	2,70A	1	0	0	1
4,0A	2,85A	1	0	1	0
4,2A	3,00A	1	0	1	1
4,4A	3,10A	1	1	0	0
4,6A	3,25A	1	1	0	1
4,8A	3,40A	1	1	1	0
5,0A	3,55A	1	1	1	1

LEDs

LED1	VCC	Logic voltage (5V) is present
LED2	Status	Driver is active, motor is under current
LED3	Error	Output for fault signals
LED4	Overvoltage	Supply voltage is too high

Options

Brake

Makes it possible to control a motor brake automatically depending on the level of the enable signal. Motorbrakes commonly use 24V=, which must be supplied externally (if the driver voltage is different to 24V). One connector of the brake is connected to +24V, the other end to connector X3.3. Connect X3.4 to ground. Before the brake is disabled, current will be applied to the motor to ensure that full holding torque is available. When disabling the driver, the brake is activated (=switched off) before the motor is deenergised.

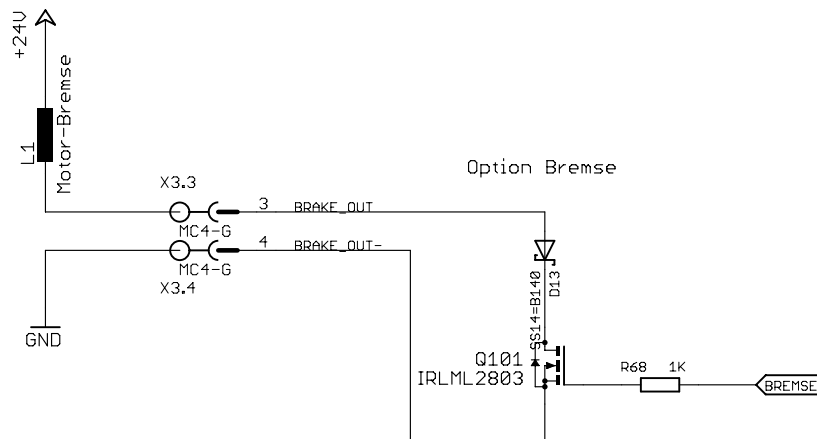

Analog input (speed control)

Devices with option „analog input“ allow for a speed control of the motor by using the analog input as speed reference signal. The rotational speed of the motor is proportional to the analog input value (range: +/-10V). The maximum speed is set to 10 rev/s at 10V input as default. Other settings can be realised as customer specific options.

The following solutions are prepared in hardware and can be used for customer specific solutions

Limit switch

Can be used for automatic reference movements, e.g. for a sequence control.

Encoder

Control the turning angle (e.g. for stall detection) or for closed loop operation of the motor.

Bus connector

Allows to link the driver to a master controller, e.g. with RS-232, RS-485 or CANopen.

Timing

Timing for signals /Step, Dir and current reduction (/Sleep)

Timing /Step, Dir und Stromabsenkung

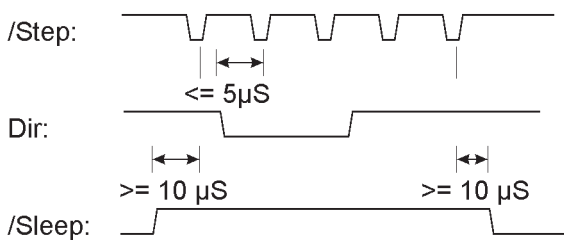

Delay between clock input (/Step) and /Home output signal

Verzögerung zwischen Takteingang und Ausgang Home

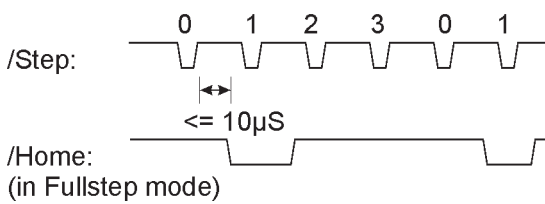

Delay between /Disable input, motor current and first /Step pulse.

Verzögerung zwischen /Disable, Motorstrom und erstem möglichen Takt

Haltezeit der Bremse (optional)

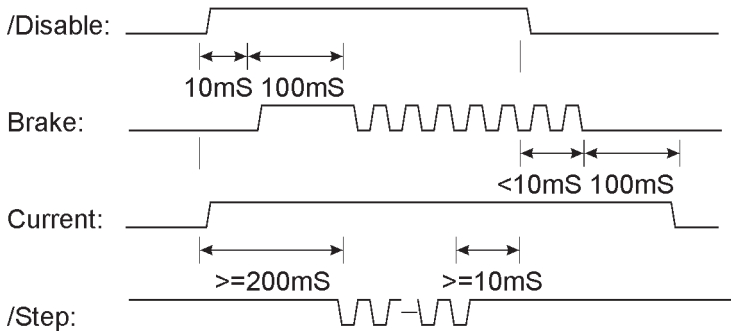

Notes:

Dimensions:

